

Series 017135FW

UL/FM AWWA RESILIENT WEDGE OS&Y GATE VALVE, FLANGED

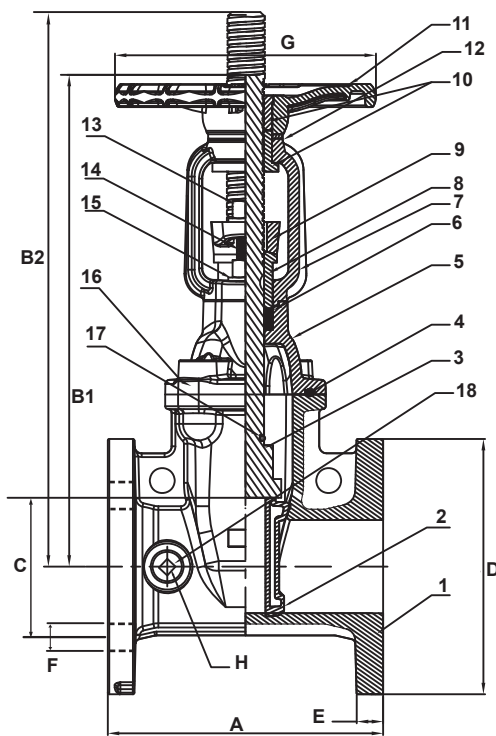

- 300 lb. non-shock cold working pressure
- Ductile iron body and bonnet
- 304 Stainless Steel stem
- Wax encapsulated stainless cap screws
- Fusion bonded epoxy coating AWWA C550
- Meets AWWA C515
- Certified to ANSI/NSF 61 & 372 (Lead Free)
- UL Listed / FM Approved
- Grooved stem for tamper switch
- Pre-tapped and plugged for by-pass with additional bosses
-  Brand for full traceability



No.	Part	Material
1	Body	Ductile Iron Gr. A536 65-45-12
2	Wedge	Ductile Iron Gr. A536 65-45-12; EPDM
3	Stem	304 Stainless Steel
4	Bonnet Gasket	EPDM
5	Bonnet	Ductile Iron Gr. A536 65-45-12
6	Stem Packing	EPDM
7	Yoke	Ductile Iron Gr. A536 65-45-12
8	Packing Gland	Brass ASTM B124 C37700
9	Gland Flange	Ductile Iron A536 65-45-12
10	Yoke Nut	Brass ASTM B124 C37700
11	Handwheel	Ductile Iron Gr. A536 65-45-12
12	Washer	Brass ASTM B124 C37700
13	Gland Nut	304 Stainless Steel
14	Stud	304 Stainless Steel
15	Flat Washer	304 Stainless Steel
16	Bonnet Bolt	304 Stainless Steel
17	O-Ring	EPDM
18	Plug	Lead Free Bronze B584 /C89833

Size IN	Part Number	Weight LB	A IN	B1 IN	B2 IN	BC* IN	D IN	E IN	F IN	G IN	H IN
2-1/2	017135FW024	39	7.50	14.68	17.32	5.50	7.00	0.69	4 - 0.75	7.10	1/2-14NPT
3	017135FW030	51	8.00	16.06	19.29	6.00	7.50	0.75	4 - 0.75	7.90	1/2-14NPT
4	017135FW040	71	9.00	18.54	22.56	7.50	9.00	0.75	8 - 0.75	10.00	1/2-14NPT
6	017135FW060	117	10.50	23.66	29.72	9.50	11.00	0.75	8 - 0.88	12.00	3/4-14NPT
8	017135FW080	201	11.50	30.47	38.38	11.75	13.50	0.87	8 - 0.88	15.75	3/4-14NPT
10	017135FW100	296	13.00	36.97	46.97	14.25	16.00	0.94	12 - 1.00	17.50	3/4-14NPT
12	017135FW120	440	14.00	41.93	53.94	17.00	19.00	1.00	12 - 1.00	17.70	3/4-14NPT

* Bolt Circle

USA 800-766-0076

Fax 323-890-4456

www.smithcooper.com

Los Angeles, CA

Chicago, IL

Atlanta, GA

Vancouver, WA